

Standards and Standardisations

Motors in the TECA, ECOL TA & ECOL TC design comply with the following Standards:

RATINGS AND PERFORMANCES
IEC 60034-1 CEI EN 60034- 1

METHODS FOR DETERMINING LOSSES AND EFFICIENCY IEC 60034-2 CEI EN 60034-2

ROTATING ELECTRICAL MACHINES, PART 30, EFFICIENCY CLASSES OF SINGLE SPEED, THREE-PHASE INDUCTION MOTORS (IE CODE)
IEC 60034-30 edition 1

CLASSIFICATION OF DEGREES OF PROTECTION (IP CODE) IEC 60034-5 CEI EN 60034-5

METHODS OF COOLING (IC CODE)
IEC 60034 - 6 CEI EN 60034-6

CLASSIFICATION OF TYPE OF CONSTRUCTION MOUNTING ARRANGEMENTS (IM CODE)
IEC 60034-7 CEI EN 60034-7

TERMINAL MARKINGS AND DIRECTION OF ROTATION
IEC 60034-8 CEI 2-8

NOISE LIMITS
IEC 60034-9 CEI EN 60034- 9

BUILT-IN THERMAL PROTECTION
IEC 60034-11

STARTING PERFORMANCE OF ROTATING ELECTRICAL MACHINES
IEC 60034- 12 CEI EN 60034 - 12

MECHANICAL VIBRATIONS
IEC 60034-14 CEI EN 60034-14

DIMENSIONS AND OUTPUTS FOR ELECTRICAL MACHINES
CEI EN50347 IEC 60072-1 IEC 60072-2

The coupling dimensions are in compliance with the following standardisations:
UNEL 13113-71 for the B3 mounting and for other frame types
UNEL 13117-71 for the B5 mounting and for other frame types

The UNEL standardisations are in accordance with the IEC international standards publication 72 and relative Amendment Nr. 1.



General Features

High efficiency motors

All TEC motors are manufactured in line with the new european standard for high efficiency. (TECA and ECOL design)

The motors are totally enclosed, fan cooled, with squirrel cage rotor.

IEC 60034-30 standard defines three IE (International Efficiency) efficiency classes of single speed three-phase cage induction motors; 50Hz and 60Hz; 2,4,6 pole; rated voltage up to 1000V, duty type S1-S8 with a rated cyclic duration factor of 80% or higher operating direct on line.

- IE1 standard efficiency, S2 rated/Ex motors/45°C ambient rated motors
- IE2 high efficiency from 0,75 to 375 Kw, obligatory in Europe from 16.07.2012
- IE3 premium efficiency from 7.5 to 375 Kw, obligatory in Europe from 01.01.2015 and from 0,75 to 375 Kw obligatory in Europe from 01.01.2017

Rated Power Output (kW)	Efficiency at full load		
	2 Pole	4 Pole	6 Pole
0.75	>=80.7	>=82.5	>=78.9
1.1	>=82.7	>=84.1	>=81.0
1.5	>=84.2	>=85.3	>=82.5
2.2	>=85.9	>=86.7	>=84.3
3	>=87.1	>=87.7	>=85.6
4	>=88.1	>=88.6	>=86.8
5.5	>=89.2	>=89.6	>=88.0
7.5	>=90.1	>=90.4	>=89.1
11	>=91.2	>=91.4	>=90.3
15	>=91.9	>=92.1	>=91.2
18.5	>=92.4	>=92.6	>=91.7
22	>=92.7	>=93.0	>=92.2
30	>=93.3	>=93.6	>=92.9
37	>=93.7	>=93.9	>=93.3
45	>=94.0	>=94.2	>=93.7
55	>=94.3	>=94.6	>=94.1
75	>=94.7	>=95.0	>=94.6
90	>=95.0	>=95.2	>=94.9
110	>=95.2	>=95.4	>=95.1
132	>=95.4	>=95.6	>=95.4
160	>=95.6	>=95.8	>=95.6
200	>=95.8	>=96.0	>=95.8
250	>=95.8	>=96.0	>=95.8
280	>=95.8	>=96.0	>=95.8
315	>=95.8	>=96.0	>=95.8
355	>=95.8	>=96.0	>=95.8
375	>=95.8	>=96.0	>=95.8
400	>=95.8	>=96.0	>=95.8

Mounting Positions

Mounting Position	Motor Frame															
	56	63	71	80	90	100	112	132	160	180	200	225	250	280	315	355
B3	*	*	*	*	*	*	*	*	*	*	*	*	*	*	*	*
B35	*	*	*	*	*	*	*	*	*	*	*	*	*	*	*	*
B5	*	*	*	*	*	*	*	*	*	*	*	*	*	*	*	*
B6	*	*	*	*	*	*	*	*	*	*	*	*	*	*	*	*
B7	*	*	*	*	*	*	*	*	*	*	*	*	*	*	*	*
B8	*	*	*	*	*	*	*	*	*	*	*	*	*	*	*	*
B14	*	*	*	*	*	*	*	*	*	*	*	*	*	*	*	*
V1	*	*	*	*	*	*	*	*	*	*	*	*	*	*	*	*
V1/V5	*	*	*	*	*	*	*	*	*	*	*	*	*	*	*	*
V3	*	*	*	*	*	*	*	*	*	*	*	*	*	*	*	*
V3/V6	*	*	*	*	*	*	*	*	*	*	*	*	*	*	*	*
V5	*	*	*	*	*	*	*	*	*	*	*	*	*	*	*	*
V5/V18	*	*	*	*	*	*	*	*	*	*	*	*	*	*	*	*
V6	*	*	*	*	*	*	*	*	*	*	*	*	*	*	*	*
V6/V19	*	*	*	*	*	*	*	*	*	*	*	*	*	*	*	*
V18	*	*	*	*	*	*	*	*	*	*	*	*	*	*	*	*
V19	*	*	*	*	*	*	*	*	*	*	*	*	*	*	*	*

Foot Mount

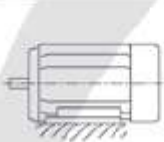

B3 (IM1001)

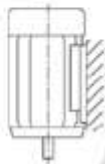

V5 (IM1011)



V6 (IM1031)

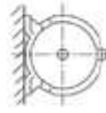

B6 (IM1051)



B7 (IM1061)

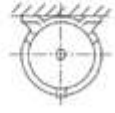

B8 (IM1071)

Large Flange

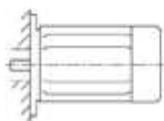

B5 (IM3001)



V1 (IM3011)



V3 (IM3031)

Large Flange and feet

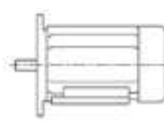

B3/B5 (IM2001)



V1/V5 (IM2011)



V3/V6 (IM2031)

B14 Face

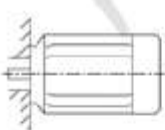

B14 (IM3601)

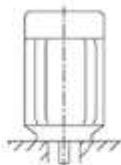

V18 (IM3611)



V19 (IM3631)

B14 face and feet

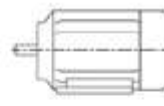

B3/B14 (IM2101)

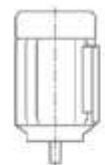

V5/V18 (IM2111)



V6/V9 (IM2131)

Protection

TEC motors are manufactured in compliance with IEC 60034-5 standards.

IP55 (standard) totally enclosed motors, fan cooled, protected against penetration from dust and water ingress coming from any direction.

IP56/IP65 (upon request) totally enclosed motors, fan cooled, protected against dust penetration and weatherproof, for use on deck.

Normally IP56/IP65 motors are supplied with external fan (IC 411 - IC 416 or IC 418). Upon request they can be supplied without fan (IC 410). In this case the features, outputs and technical data will be supplied upon request.

The cooling fan is protected by a fan cowl with IP20 protection degree, in line with safety standards. Motors for vertical mounting V 1, V5, V1N5 can be supplied with rain canopy. The terminal box, in aluminium or cast iron, has IP55 or IP56 protection degree.

General Construction Features

The motors have been designed and manufactured in compliance with international standards.

TECA and ECOL TA aluminium designs are available in frame sizes 56-200. The fan cowl is made from steel sheet. Flanges and end-shields are aluminium.

ECOL TC and TECC cast iron designs are available in frame sizes 132 - 355. The fan cowl is made from steel sheet. Flanges and end-shields are cast iron.

Terminal boxes as standard are on the top of the motor, they can be rotated in steps of 90°. The end user can modify the terminal box to be on the left or the right side in frame sizes 56 to frame size 280.

Fans are in nylon, upon request can be supplied with fans in aluminium or steel. Feet are detachable on all series, from frame sizes 56 to frame size 280.

Cooling

The designation of cooling method is given by the IC (International Cooling) code, according to IEC 60034-6

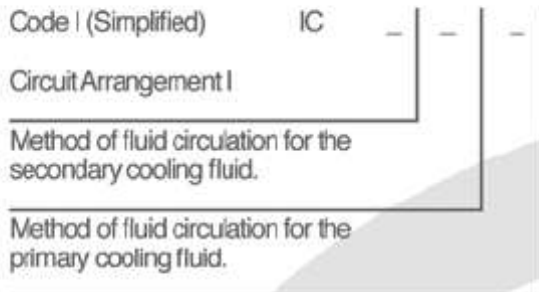

Motors in standard production from 56 to 355 are supplied with IC 411 cooling systems, incorporating a bi-directional fan.

All frame sizes can be supplied with cooling system IC 416 on request.

In this case an additional fan is fitted inside the fan cover, suitably reinforced, in order to make the ventilation independent of the motors rotational speed.

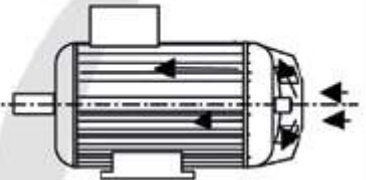
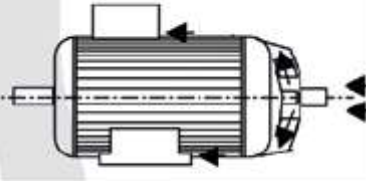
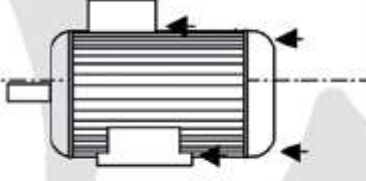
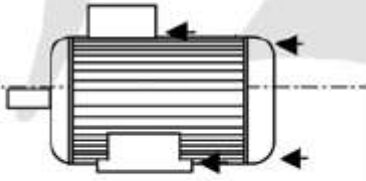
IC CODE	FIGURE	DESCRIPTION	NOTE
IC 411		Self ventilating motor. Enclosed machine. Externally finned. External shaft-mounted fan.	Standard
IC 416		Motor with assisted ventilation. Enclosed machine. Externally finned. Independent external fan mounted inside the fan cover.	Upon request
IC 418		Motor with external ventilation. Enclosed machine. Externally finned ventilation provided by air flowing from the driven system.	Upon request
IC 410		Motor with natural ventilation. Enclosed machine.	Upon request

Bearings

TECA and ECOL TA designs from frame size 56 to frame size 200 have sealed for life pre-lubricated ball bearings, DE and NDE side, C3 clearance. ECOL TC designs in frame sizes up to 132 have sealed for life pre-lubricated ball bearings, DE and NDE side, C3. ECOL TC designs from frame size 160 to frame size 280 (including 315 2 pole) have open ball bearings, DE and NDE, C3. ECOL TC designs from frame size 315 (4, 6, 8 pole) to frame size 355, have roller bearings DE side and ball bearings NDE side. All non sealed bearings need to be periodically re-lubricated according to the data given in the motors operation and maintenance manual. All motors are fitted with thrust washers in order to minimise vibration. Locked bearing options are available upon request. The lifetime of bearings (in accordance with supplier data) is in excess of 40,000 hours, for motors with direct coupling.

In table are mentioned all specifications concerning bearings installed in motors frame size 56-355.

MOTOR TYPE	POLES	MOUNTING B3		MOUNTING B5/B14	
		Bearing coupling side DE	Bearing opposite coupling side NDE	Bearing coupling side DE	Bearing opposite coupling side NDE
TA/MS 56	2-4-6-8	6201-2RS-C3	6201-2RS-C3	6201-2RS-C3	6201-2RS-C3
TA/MS 63	2-4-6-8	6201-2RS-C3	6201-2RS-C3	6201-2RS-C3	6201-2RS-C3
TA/MS 71	2-4-6-8	6202-2RS-C3	6202-2RS-C3	6202-2RS-C3	6202-2RS-C3
TA/MS 80	2-4-6-8	6204-2RS-C3	6204-2RS-C3	6204-2RS-C3	6204-2RS-C3
TA/MS 90	2-4-6-8	6205-2RS-C3	6205-2RS-C3	6205-2RS-C3	6205-2RS-C3
TA/MS 100	2-4-6-8	6206-2RS-C3	6206-2RS-C3	6206-2RS-C3	6206-2RS-C3
TA/MS 112	2-4-6-8	6306-2RS-C3	6206-2RS-C3	6306-2RS-C3	6206-2RS-C3
TA/MS 132	2-4-6-8	6308-2RS-C3	6208-2RS-C3	6308-2RS-C3	6208-2RS-C3
TA/MS 160	2-4-6-8	6309-2RS-C3	6209-2RS-C3	6309-2RS-C3	6209-2RS-C3
TA/MS 180	2-4-6-8	6311-2RS-C3	6211-2RS-C3	6311-2RS-C3	6211-2RS-C3
TA/MS 200	2-4-6-8	6312-2RS-C3	6212-2RS-C3	6312-2RS-C3	6212-2RS-C3
TC 132	2-4-6-8	6308ZZ-C3	6308ZZ-C3	6308ZZ-C3	6308ZZ-C3
TC 160	2-4-6-8	6309-C3	6309-C3	6309-C3	6309-C3
TC 180	2-4-6-8	6311-C3	6311-C3	6311-C3	6311-C3
TC 200	2-4-6-8	6312-C3	6312-C3	6312-C3	6312-C3
TC 225	2-4-6-8	6313-C3	6313-C3	6313-C3	6313-C3
TC 250	2-4-6-8	6314-C3	6314-C3	6314-C3	6314-C3
TC 280	2-4-6-8	6316-C3	6316-C3	6316-C3	6316-C3
TC 315	2	6317-C3	6317-C3	6317-C3	6317-C3
TC 315	4-6-8	NU319	6319-C3	NU319	6319-C3
TC 355	2	6319-C3	6319-C3	6319-C3	6319-C3
TC 355	4-6-8	NU322	6322-C3	NU322	6322-C3

Upon request motors can be modified with roller bearings at the DE, where non-standard, insulated bearings at the NDE and angular contact bearings at the DE.

PLEASE NOTE:

TEC motors in frames 280-355 frame in 4,6 and 8 pole are fitted with an NU roller bearing as standard at the drive end.

TEC recommend that a "7 series" angular contact bearing is fitted onto any motor 250 frame and above for vertically mounted shaft down applications.

Terminal Box

The terminal block is normally equipped with 6 terminal and is made of non hygroscopic and mildew resistance material. Terminal box for the TECA and ECOL TA design is made of aluminum and cast iron or tin for the ECOL TC design.

All terminal boxes are IP55 as standard.

Terminal boxes in the TECA and ECOL TA designs from size 56 to size 90 are fitted with a cable-gland and a plug. Size 100 to size 200 are fitted two cable-glans.

Terminal boxes in the ECOL TC design are fitted with two cable-glans. ECOL TC motors in frame 160 and above are fitted with an addition M16 auxiliary gland. The below table shows which gland sizes are fitted in which frame size:

FRAME	CABLE-GLAND
TA/TECA 56	1-M20x1,5
TA/TECA 63	1-M20x1,5
TA/TECA 71	1-M20x1,5
TA/TECA 80	1-M20x1,5
TA/TECA 90	1-M25x1,5
TA/TECA 100	1-M25x1,5
TA/TECA 112	2-M25x1,5
TA/TECA 132	2-M32x1,5
TA/TECA 160	2-M32x1,5
TA/TECA 180	2-M40x1,5
TA/TECA 200	2-M40x1,5
TC 132	2-M25x1,5
TC 160	2-M32x1,5+1M16x1,5
TC 180	2-M32x1,5+1M16x1,5
TC 200	2-M40x1,5+1M16x1,5
TC 225	2-M50x1,5+1M16x1,5
TC 250	2-M50x1,5+1M16x1,5
TC 280	2-M63x1,5+1M16x1,5
TC 315	2-M63x1,5+1M16x1,5
TC 355	2-M63x1,5+1M16x1,5

Connection

Motors 4.0kw and above are usually delta connected (Δ)(400v) to allow star-delta starting (Y/ Δ). Motors 3.0kw and below are usually star connected (Y)(400v) which gives the option of a 230/3/50 supply (Δ) for 1ph-3ph frequency drive connection.

Upon request and for particular applications, based on the powers and supply voltages, motors can be star connected (Y). Wiring diagrams are shown in the operation and maintenance manual and attached to each motor.

MS Three Phase Motors

Star Connection

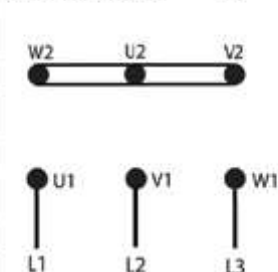

Connect links as shown below

Delta Connection

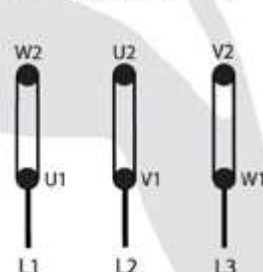

MY Single Phase - Perm Cap

Clockwise Rotation

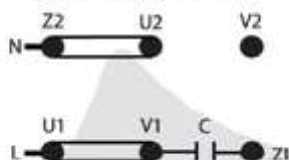

Anti Clockwise Rotation

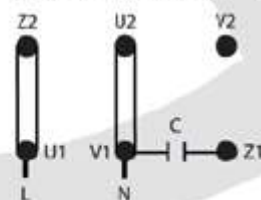

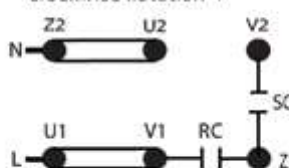

ML Single Phase - Cap Start / Cap Run

Clockwise Rotation

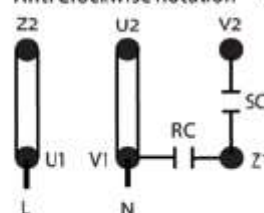

Anti Clockwise Rotation





3~ Mot | TYPE: 0.5543TECAB34 MS 801-4

S1-100%	IEC60034	IP 55	IM B34	
SN No. 1204-06803851	Ins.Cl. F	NW: 8.8	KGS	

V	Hz	min ⁻¹	kW	A	cos φ	Eff.
230 V Δ	50	1370	0.55	2.74	0.75	87 %
400 V Y	50	1370	0.55	1.58	0.75	87 %
276 V Δ	60	1640	0.66	2.74	0.75	DE 6294 ZZ
480 V Y	60	1640	0.66	1.58	0.75	NDE 6294 ZZ

Distributed by  Electric Motors

Insulation & Windings

All TEC motors are manufactured as standard with Class F insulation.

Soft copper electrolytic wire is insulated using a special enamel (double enamel). The type of enamel is classified as H insulation class. All insulating materials used to produce motors are in F or H insulation class.

The winding manufacturing process is as follows: initially the winding is impregnated by soaking it in oven-curing F class resins, it is tropicalized following a process including a spraying of anti-saline enamel and, finally, it is coated using a spray with heatproof, humidity-proof, chemical agent and sea-ambient corrosive action resistant characteristics.

The impregnation cycle is carried out under vacuum conditions (vacuum impregnation process) VPI.

Ratings & Technical Data

Power and data reported in the Technical Data Tables are based on continuous duty (S 1) at an ambient temperature of 40 C, max. altitude 1000 a.s.l., with supply at 400 V - 50Hz.

In such conditions, the temperature rise reached by the motors is lower than the one provided for by the H insulation class.

The operating characteristics are guaranteed with the tolerances defined by the CEI EN 60034-1 Standards and the IEC 60034-1 Recommendations, reported in the table:

CHARACTERISTICS	TOLERANCES
Efficiency	Motor power < 50 kW -15% di (1 - η) Motor power > 50 kW -10% di (1 - η)
Power factor	+1/6 (1 - $\cos\phi$) Min 0.02 Max 0.07
Locked rotor current	+20% of guaranteed value
Locked rotor torque	-15% + 25% of guaranteed value
Pull out torque	-10% of guaranteed value
Slip	\pm 20% of guaranteed value

Voltage & Frequency Variations

Motors will work as expected if the supply voltage variations are limited as stated in the Classification Society Standards.

In particular, motors can run with voltage variations of 10% and frequency variations of 5% with a maximum combined variation of 10% and within the temperature rise as stated by the provisions of the Classification Society Standards.

Operation At 60HZ Frequency

The motors will run with a frequency of 60Hz with differences in performance and electrical power applying the multiplier coefficient as detailed below. Motors made at 50Hz but supplied with 60Hz may have varying output efficiencies compared to the 50Hz values

PLATE VOLTAGE 50 HZ	PLATE VOLTAGE 60 HZ	NOMINAL POWER	NOMINAL CURRENT	NOMINAL TORQUE	RPM	STARTING CURRENT	STARTING TORQUE	MAX TORQUE
230 +/- 10%	220 +/- 5%	1.00	1.00	0.83	1.20	0.83	0.83	0.83
230 +/- 10%	230 +/- 10%	1.00	0.95	0.83	1.20	0.83	0.83	0.83
230 +/- 10%	254 +/- 5%	1.15	1.02	0.96	1.20	0.93	0.93	0.93
230 +/- 10%	277 +/- 5%	1.20	1.00	1.00	1.20	1.00	1.00	1.00
400 +/- 10%	380 +/- 5%	1.00	1.00	0.83	1.20	0.83	0.83	0.83
400 +/- 10%	400 +/- 10%	1.00	0.95	0.83	1.20	0.83	0.83	0.83
400 +/- 10%	440 +/- 5%	1.15	1.02	0.96	1.20	0.93	0.93	0.93
400 +/- 10%	460 +/- 10%	1.15	1.00	0.96	1.20	0.96	0.96	0.96
400 +/- 10%	480 +/- 5%	1.20	1.00	1.00	1.20	1.00	1.00	1.00

De-rating

The technical data tables refer to an ambient temperature of 40°C and an altitude up to 1000 a.s.l. In different environmental conditions output ratings vary, and are calculated by applying the factors as mentioned in the table below, maintaining the temperature rise provided for by the F insulation class.

ALTITUDE M A.S.L.	AMBIENT TEMPERATURE (°C)					
	30	30-40	45	50	55	60
<= 1000	1.06	1.00	0.97	0.94	0.90	0.87
1500	1.04	0.97	0.94	0.91	0.87	0.84
2000	1.00	0.95	0.92	0.88	0.84	0.81
3000	0.96	0.89	0.86	0.82	0.78	0.74
4000	0.91	0.84	0.80	0.76	0.72	0.67

Duties

All technical data reported in the tables are referred to continuous duty (S1). Upon request, motors for limited Duty S2 (30 or 60 minutes) can be supplied.

Overloads

Continuous duty motors can withstand the following overloads

OVERLOAD %	DURATION MINUTES	TIME INTERVAL MINUTES
10	10	15
20	6	15
30	4	15
40	3	15
50	2	15

In these operating overloads conditions, over temperatures are then limited to insulation class F.

Starting

Motors are suitable for the following types of starting:

- Direct
- Star - delta (400/690v only)
- By autotransformer
- Soft-start (*)
- by inverter (**)

(*)After starting is completed, the soft-start should be by-passed, precautions must also be taken when the motor is powered by an inverter

(**) see recommendation in paragraph n.23 "Inverter Supply"

Vibration

Motors are dynamically balanced with a half key applied to the shaft extension in accordance with standard IEC 60034-14 to vibration severity grade reduced (R) in standard execution.

The following table indicates the maximum vibration grades with respect to the different shaft heights.

VIBRATION DEGREE	RATED SPEED	FRAME SIZE 56-355 Vmm/sec
N (normal)	600-1800	1.8
R (reduced)	600-1800	0.71
	1800-3600	1.12
S (special)	600-1800	0.45
	1800-3600	0.71

Noise

The technical features detailed in the table below contain the values of A-sound pressure level (LpA) and A sound power level (LwA), measured at a one meter distance.

Sound levels are measured in no-load conditions and have tolerances of +/- 3 dB(A).

FRAME SIZE	A-sound pressure level (LpA) - A-sound power level (LwA) dB(A)							
	2POLES		4POLES		6POLES		8POLES	
	LpA	LwA	LpA	LwA	LpA	LwA	LpA	LwA
56	69	78	63	72	58	67	54	63
63	75	84	67	76	61	70	58	67
71	75	84	67	76	61	70	58	67
80	75	84	70	79	63	72	61	70
90	75	85	70	80	66	76	66	76
100	77	87	70	80	66	76	66	76
112	78	88	73	83	66	76	66	76
132	69	78	63	72	58	67	54	63
160	75	84	67	76	61	70	58	67
180	75	84	67	76	61	70	58	67
200	75	84	70	79	63	72	61	70
225	75	85	70	80	66	76	66	76
250	77	87	70	80	66	76	66	76
280	78	88	73	83	66	76	66	76
315	80	90	77	87	73	83	69	79
355	86	97	84	96	82	94	79	91

The values of the noise (LpA) and of the sound power (LwA) in the table are related to the operation at 50Hz, when the frequency changes these values change how indicated in the following table:

SUPPLY FREQUENCY HZ	% NOISE LEVEL COMPARED TO THE 50HZ VALUE
10	60%
20	60%
30	70%
40	100%
50	100%
60	100%
80	120%

Thermal Protection

All 3ph TEC motors from frame size 56 to frame size 355 are fitted with positive temperature coefficient thermistors (PTC), these thermal devices, at the designed temperature, quickly change their standard resistance value. These PTC's, upon request, can be installed in 1ph motors.

Resistance of PTC, for nominal operating temperature (TK), will be satisfy the following value:

- < 250 Ohm from temperature from -20°C to TK-20°C
- < 550 Ohm at a temperature of TK-5°C
- > 1330 Ohm at a temperature of TK+5°C
- > 4000 Ohm at a temperature of TK +15°C

In line with the standards, PTC's are designed for resistance value from 1650 Ohm to 4000 Ohm, in our case, installed n. 3 PTC in series, disengaged takes in the temperature range from TK-5°C to TK+5°C. Values of TK related with the class of insulation are the following:

CLASS OF INSULATION	OPERATING TEMPERATURE LIMIT OF THE INSULATION °C	TK °C
A	105	95-100
E	120	110-115
B	130	120-125
F	155	145-150
H	180	170-175

The nominal operating temperature of the thermistors PTC, mounted on TEC motors is 130° C in the TECA and ECOL TA designs. ECOL TC design motors have 150°C PTC's fitted. The maximum supply voltage of the PTC thermistors is 2,5V. Below the characteristic resistance/ temperature of the PTC thermistors:

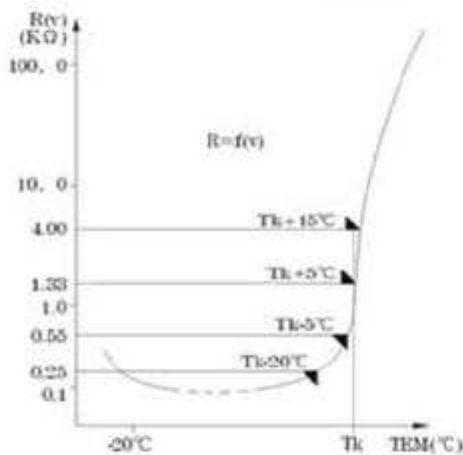

Upon request, the following thermal protections can be installed on the motors:

Bimetallic devices

Motor protectors with contact normally closed. The contact opens when the winding temperature reaches limits dangerous to the insulation system of the motor.

Platinum resistance thermometers PT100

Variable linear resistance with the winding temperature. This device is especially suitable for continuous winding temperature monitoring.

The protection is normally made by 3 sensitive elements, one for every phase, series connected and with two terminals in a specially provided terminal board located in the main terminal box or in a specially provided auxiliary terminal box.

Anti-Condensation Heaters

Motors subject to atmospheric condensation, either through standing idle in damp environments or because of wide ambient temperature variations, may be fitted with anti-condensation heaters.

They are of tape form and are normally mounted on the stator winding head.

Anti-condensation heaters are normally switched on automatically when the supply to the motor is interrupted, heating the motor to avoid water condensation.

Normal supply voltage is 110/115V or 220/240V.

Anti-condensation heater terminals are led to a specifically provided terminal board located in the main terminal box. Upon request they can be led to a terminal board located in an auxiliary terminal box.

The power values normally used are shown in the table:

FRAME SIZE	POWER (W)
132-160	26
180-200	26
225 - 250	50
280 - 315	100
355	200

Drain Holes

TEC Motors in 56-355 frame are equipped with drain holes at DE and NDE for the discharge of condensation, closed with a plug to guarantee the IP integrity (ingress protection) stated on the plate.

As a function of the operating conditions such plugs can be removed to allow the discharge of condensation that may form inside the motor. The holes are fitted ready for B3 mounting position as standard but can be fitted elsewhere on request.

Inverter Supply

All TEC 3ph motors are designed to be used in conjunction with an inverter. These motors can be driven up to the rated frequency (50Hz) with supply voltage proportional to the frequency. (See diag 1), at higher frequencies they can be supplied at constant voltage up to the level of 80Hz.

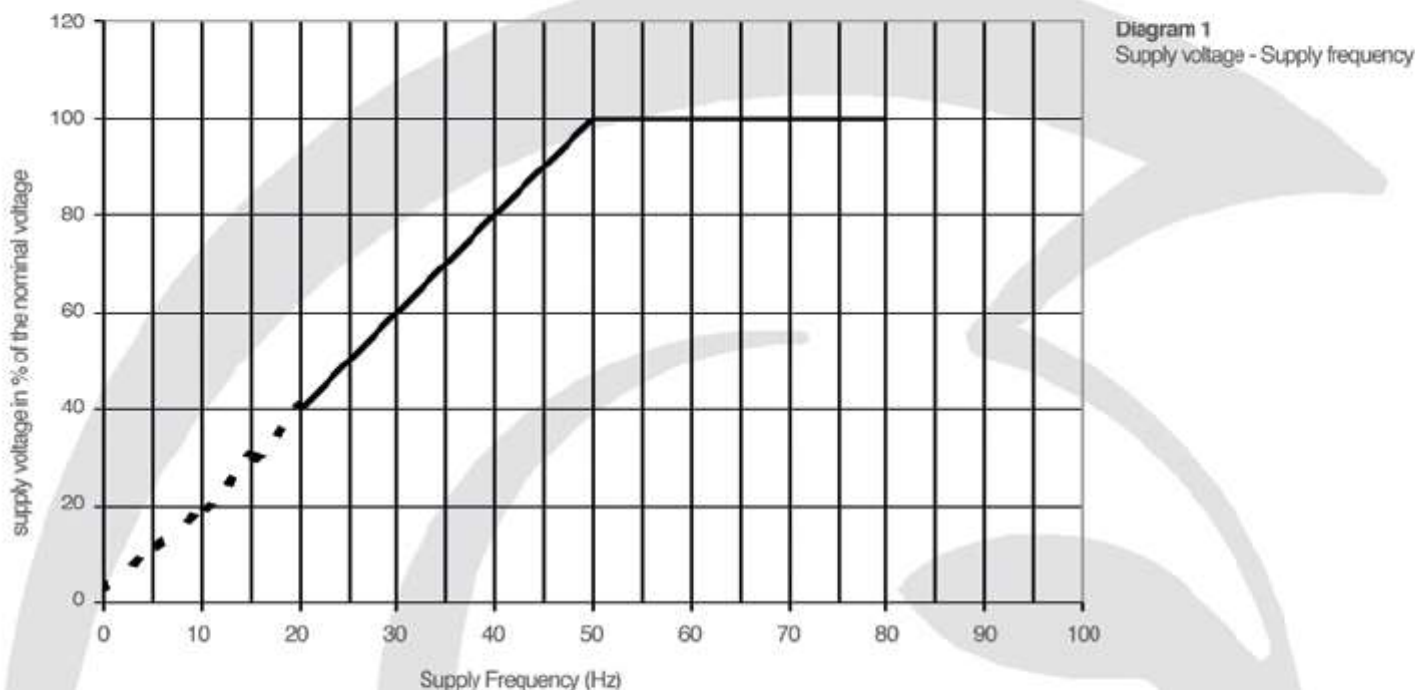

Using as per the supply shown in diag 1, the flux created by the stator windings will be constant from 0 frequency to 50 Hz frequency, at frequencies higher than 50 Hz, the flux will be lower than the maximum value.

Note: At low frequencies (0 ~ 10Hz.) due to voltage drop, in order to keep the flux constant, the supply voltage should be slightly increased. This voltage increase depends both on the motor type and on the inverter type.

Consequently the motors in standard production (self ventilating code IC411) are able to run at constant torque between 40 and 50 Hz and at constant power in the section included between 50 and 80 Hz (see diagram 2 and 3).

Upon request, the EG line motors can be equipped with an auxiliary fan (code IC 416), in this case they can supply a constant torque between 0 and 50 Hz and a constant power in the section included between 50 and 80 Hz.

Inverter Supply Continued

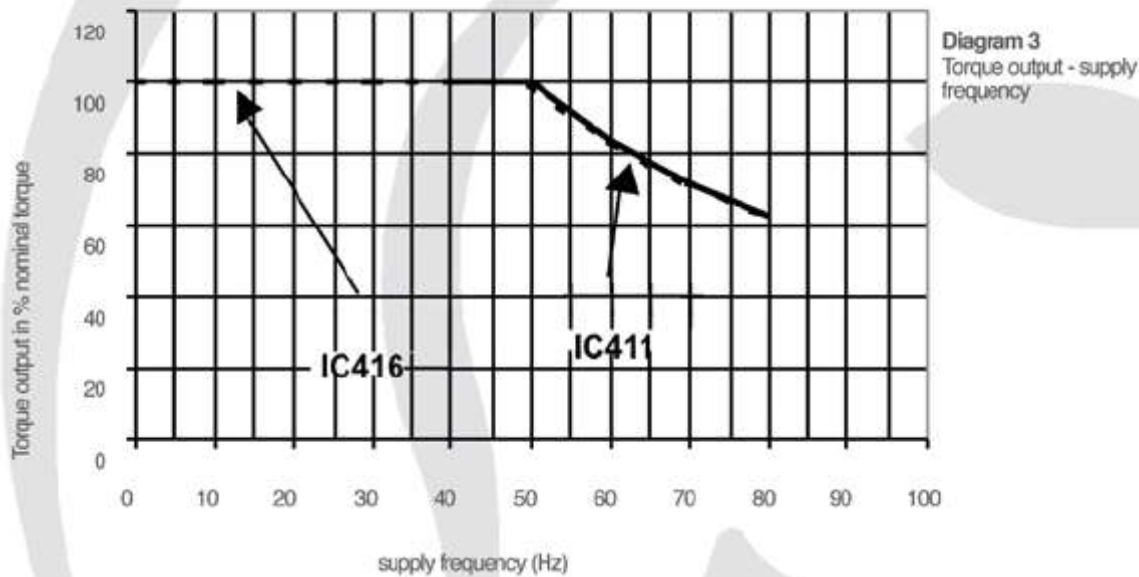
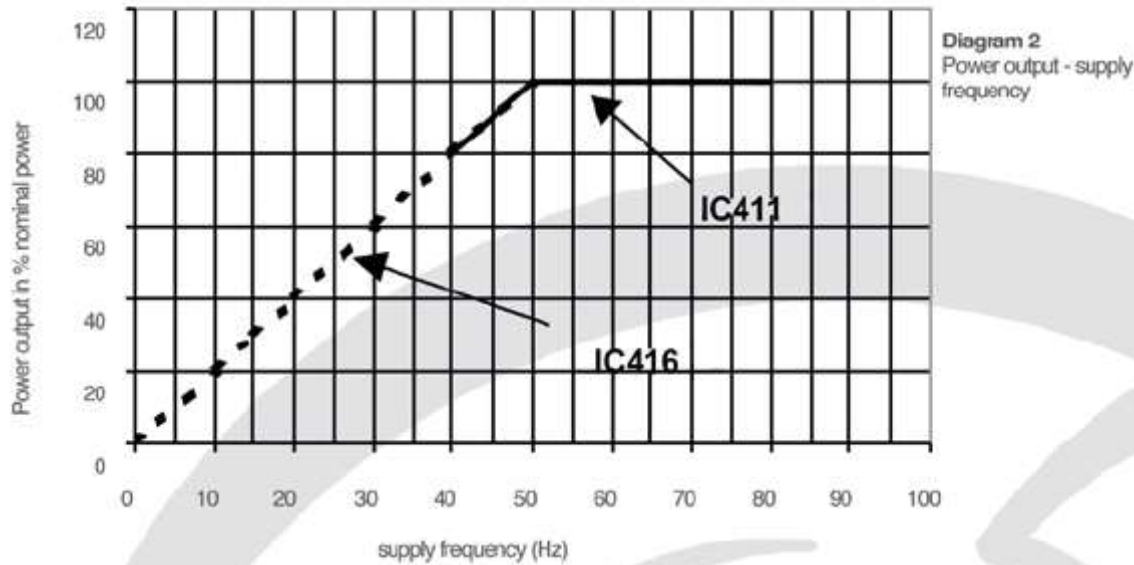

The asynchronous three-phase motors to be used for inverter supply are designed and manufactured based on design and manufacturing choices that allow an optimum and reliable operation.

It has to be considered that generally the inverter supplies the asynchronous motor with a non sinusoidal current having a certain harmonic contents. This is due in particular: to the type of inverter, to the value of the switch frequency, to the length of the supply cables. Moreover steep voltage fronts to the motor terminals (dv/dt) originated by the short commutation times of the IGBT, generate considerable stresses on the insulating materials.

Consequently the motor insulation must be carefully fitted and selected in order for it to be able to withstand such high stresses. All TEC motors are fitted with phase to phase barrier insulation suitable for inverter use.

Maximum Speed

Motors supplied by inverter can run at a frequency higher than the rated level supplying the rated power up to the maximum frequency mentioned in table.

In these conditions the motor maximum torque remains 1.6 times higher than the rated torque.

FRAME SIZE	MAX SUPPLY FREQUENCY (Hz)			
	2 POLES	4 POLES	6 POLES	8 POLES
56 - 90	75	75	60	60
100 - 112	70	70	60	60
132 - 160	65	65	60	60

It is also possible to supply motors at an higher frequency, in this case the deliverable motor powers will be progressively reduced. In such cases the motor maximum speeds, also at no load operation or loaded by the machine, must never exceed the limit mentioned in the following table:

FRAME SIZE	MAX PERMISSIBLE SPEED			
	2 POLES	4 POLES	6 POLES	8 POLES
132	5000	5000	4500	4500
160	5000	5000	4500	4500
180	5000	5000	4500	4500
200	5000	5000	4500	4500
225	4500	4500	4000	4000
250	4000	4000	3800	3800
280	4000	3000	3000	3000
315	3600	2600	2600	2600
355	3600	2600	2600	2600

Auxiliary Fans

All frame sizes can be supplied with cooling system IC 416 (forced ventilation) on request. In this case a suitable fan is fitted inside the fan cover and suitably reinforced. TEC always recommend forced ventilation on motors used below 25hz or above 75hz. Consequently the ventilation is independent of the rotation speed of the motor itself. This solution is particularly suitable for inverter supplied motors.

FRAME SIZE	THREE PHASE SUPPLY VOLTAGE 230/400V	SUPPLY FREQUENCY 50HZ	INPUT POWER W	SINGLE PHASE SUPPLY VOLTAGE 230V	SUPPLY FREQUENCY HZ	INPUT POWER W
63	230/400	50	20	230	50	17
71	230/400	50	25	230	50	33
80	230/400	50	29	230	50	35
90	230/400	50	32	230	50	45
100	230/400	50	58	230	50	30
112	230/400	50	69	230	50	35
132	230/400	50	52	230	50	32
160	230/400	50	70	230	50	50
180	230/400	50	85	230	50	47
200	230/400	50	105	230	50	49
225	230/400	50	105	230	50	70
250	230/400	50	115	230	50	126
280	230/400	50	180	230	50	149
315	230/400	50	480	230	50	-
355	230/400	50	400	230	50	-

The following table shows the increase that is applicable to dimension L (overall length) when independent ventilation is mounted. When an encoder is mounted with independent ventilation, dimension L does not change and remains the same as the motor with independent ventilation.

FRAME SIZE	TECA SERIES mm	TA SERIES mm	TC SERIES mm
63	92	92	-
71	92	105	-
80	98	110	-
90	97	110	-
100	103	120	-
112	93	125	-
132	109	120	120
160	-	145	130
180	-	-	130
200	-	-	140
225	-	-	160
250	-	-	167
280	-	-	175
315	-	-	205
355	-	-	205



Permissible Bearing Load

The theoretical basic fatigue life for bearings is calculated according to the provisions of the ISO R 281-1 Standard. Life is calculated assuming that motors are running under normal ambient conditions, without abnormal vibrations, without axial or radial loads beyond the ones detailed in the following tables and with operating temperatures of the bearings ranging between -30 and +85 C°.

Life calculated this way is called basic life (L_{10}) expressed in hours of operation.

50% of bearings reach a life equal to five times the basic life resulting from the calculation.

The values in table 13 are the maximum permitted axial and radial loads for a basic life (L_{10}), and are calculated according to the provisions of the ISO Standards, equal to 20000 and 40000 hours of operation.

Values of the radial loads are given both for loads applied to the shaft extension (X_{max}) and in correspondence of the face on the shaft housing (X_0).

Radial loads that can be applied linearly, change with the change of the application point, therefore for loads placed at a distance from the shaft face (X_0), the maximum load that can be applied is given as the following expression:

$$Fra_x = \frac{C_{x_0} - C_{x_{max}}}{X_{max}} \times X + C_{x_{max}}$$

Where:

Fra_x = permitted radial load at point X

C_{x_0} = permitted radial load at point X_0

$C_{x_{max}}$ = permitted radial load at point X_{max}

X_{max} = shaft extension

X = distance from the application point of the radial load to the shaft face

To verify that belt tension does not exceed the maximum value allowed the following formula can be used:

$$F = \frac{19100 \times P \times K}{n \times D}$$

F = radial force in Nm

P = power transmitted in KW

n = numbers of revs. per minute

D = pulley diameter in meters

K = constant

Constant values K:

2	for flat pulley with tension roller
2,25	for sheaves with V belt
2,5-3	for flat belts without tension roller, or for heavy duty with any type of pulley

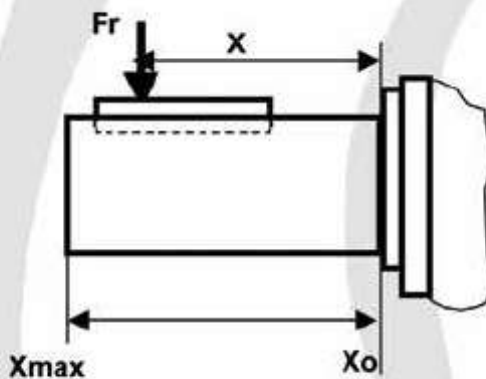

TECA “MS” DESIGN



ELECTRICAL AND DIMENSIONAL DATA

The TECA series aluminium housed motor is a 3 phase multi-mount motor available from 56-200 frame (IEC). TECA motors are manufactured to IEC standards using the latest automated production technology.

TECA motors are easily maintained, lightweight with high performance and low noise levels. The multi-mount design gives end users greater flexibility where the terminal box position is important.

TECA Series - Three-Phase Asynchronous Single Speed Motors

IE1

Electrical data (50Hz) 2 pole

Frame size	Power (KW)	Current (A)			Current (A)			Current (A)			rpm. (r/min)	Eff. (%)	Power factor (Cosφ)	C _g /C _n	C _{max} /C _n	C _n (Nm)	is/in	dB(A)	Weight (Kg)
		220V	380V	660V	230V	400V	690V	240V	415V	720V									
MS 561-2	0.06	0.66	0.38	0.22	0.62	0.36	0.21	0.60	0.35	0.20	2710	53	0.72	2.2	2.3	0.502	4	56	2.60
MS 562-2	0.12	0.73	0.42	0.24	0.69	0.40	0.23	0.67	0.39	0.22	2700	61	0.72	2.2	2.3	0.534	4	58	3.00
MS 563-2	0.18	1.00	0.58	0.33	0.96	0.55	0.32	0.92	0.53	0.31	2710	63	0.75	2.2	2.4	0.642	6	61	4.00
MS 631-2	0.18	1.00	0.58	0.33	0.95	0.55	0.32	0.92	0.53	0.31	2710	63	0.75	2.2	2.4	0.641	6	61	4.00
MS 632-2	0.25	1.29	0.75	0.43	1.23	0.71	0.41	1.19	0.69	0.40	2710	65	0.78	2.2	2.4	0.884	6	61	4.20
MS 633-2	0.37	1.92	1.11	0.64	1.82	1.05	0.61	1.76	1.02	0.59	2710	65	0.78	2.2	2.4	1.261	6	62	4.70
MS 711-2	0.37	1.76	1.02	0.59	1.67	0.97	0.56	1.61	0.93	0.54	2730	70	0.79	2.2	2.4	1.292	6	64	5.20
MS 712-2	0.55	2.57	1.49	0.86	2.45	1.42	0.82	2.36	1.36	0.79	2760	71	0.79	2.2	2.4	1.899	6	64	6.00
MS 713-2	0.75	3.33	1.93	1.11	3.18	1.89	1.04	3.08	1.77	1.02	2730	72	0.80	2.2	2.4	2.54	6	65	7.00
MS 801-2	0.75	3.21	1.86	1.07	3.06	1.77	1.02	2.94	1.70	0.96	2770	73	0.84	2.2	2.4	2.54	6	67	8.70
MS 802-2	1.1	4.56	2.64	1.52	4.35	2.51	1.45	4.16	2.42	1.38	2770	76.2	0.83	2.2	2.4	3.72	6	67	10.00
MS 803-2	1.5	6.04	3.50	2.01	5.87	3.32	1.92	5.54	3.20	1.85	2800	78.5	0.83	2.2	2.4	5.04	6	70	11.20
MS 90S-2	1.5	5.97	3.46	1.99	5.76	3.28	1.90	5.47	3.16	1.82	2840	78.5	0.84	2.2	2.4	5.04	6	72	12.00
MS 90L1-2	2.2	8.99	4.85	2.56	8.0	4.01	2.06	7.69	4.45	2.50	2840	81	0.85	2.2	2.4	7.4	6	72	14.50
MS 90L2-2	3	11.1	6.42	3.69	10.6	6.10	3.52	10.2	5.88	3.36	2840	82.6	0.86	2.2	2.4	10.1	6	74	15.00
MS 100L1-2	3	11.0	6.34	3.65	10.4	6.03	3.48	10.0	5.81	3.35	2840	82.6	0.87	2.2	2.3	10.1	7	76	20.00
MS 100L2-2	4	14.3	8.30	4.78	13.7	7.88	4.55	13.1	7.60	4.36	2850	84.2	0.87	2.2	2.3	13.4	7.5	77	24.00
MS 112M-2	4	14.3	8.30	4.78	13.7	7.88	4.55	13.1	7.60	4.36	2880	84.2	0.87	2.2	2.3	13.4	7.5	77	26.00
MS 112L-2	5.5	18.1	11.1	6.38	18.2	10.5	6.06	17.5	10.1	5.86	2880	85.7	0.88	2.2	2.3	18.2	7.5	78	29.30
MS 132S1-2	5.5	19.1	11.1	6.38	18.2	10.5	6.06	17.5	10.1	5.85	2900	85.7	0.88	2	2.2	18.1	7.5	80	38.40
MS 132S2-2	7.5	25.7	14.9	8.57	24.5	14.1	8.16	23.6	13.6	7.86	2920	87	0.88	2	2.2	24.7	7.5	80	41.30
MS 132N1-2	9.2	30.8	17.8	10.3	29.9	17.3	9.96	29.3	16.3	9.42	2930	88	0.89	2	2.2	29.5	7.5	81	48.20
MS 132N2-2	11	36.3	21.0	12.1	34.6	20.0	11.5	33.3	19.2	11.1	2930	88.4	0.9	2	2.2	36.0	7.5	83	52.50
MS 160N1-2	11	36.3	21.0	12.1	34.6	20.0	11.5	33.3	19.2	11.1	2940	89.4	0.9	2	2.2	36.1	7.5	86	76.00
MS 160N2-2	15	48.4	28.0	16.1	46.1	26.6	15.4	44.4	25.7	14.8	2940	89.4	0.91	2	2.2	48.9	7.5	86	77.50
MS 160L-2	18.5	59.3	34.3	19.8	56.5	32.6	18.8	54.3	31.4	18.1	2940	90	0.91	2	2.2	60.1	7.5	86	92.00
MS 180M-2	22	71.3	41.3	23.8	68.2	39.2	22.6	65.3	37.8	21.6	2950	90	0.9	2	2.2	71.2	7.5	91	121.0
MS 200L1-2	30	96.0	55.6	32.1	91.8	52.8	30.5	88.0	50.9	29.4	2950	91.2	0.9	2	2.2	97.0	7.5	94	144.0
MS 200L2-2	37	117	67.9	38.2	112	64.5	37.2	108	62.2	35.8	2940	92	0.9	2	2.2	119	7.5	94	151.0

TECA Series - Three-Phase Asynchronous Single Speed Motors

IE1

Electrical data (50Hz) 4 pole

Frame size	Power (KW)	Current (A)			Current (A)			Current (A)			rpm. (r/min)	Eff. (%)	Power factor (Cosφ)	Ce/ Cn	Cmax/ Cn	Cn (Nm)	Is/In	dB(A)	Weight (Kg)
		220V	380V	660V	230V	400V	690V	240V	415V	720V									
MS561-4	0.06	0.64	0.37	0.21	0.61	0.35	0.20	0.56	0.34	0.19	1360	50	0.56	2.3	2.4	0.478	4	50	290
MS562-4	0.09	0.82	0.47	0.27	0.78	0.45	0.26	0.75	0.43	0.25	1360	52	0.59	2.3	2.4		4	50	320
MS631-4	0.12	1.00	0.58	0.33	0.95	0.55	0.32	0.90	0.53	0.31	1360	52	0.64	2.2	2.4	0.59	4	52	370
MS632-4	0.18	1.26	0.74	0.43	1.21	0.70	0.40	1.17	0.67	0.39	1310	57	0.66	2.2	2.4	1.28	4	52	420
MS633-4	0.25	1.66	0.96	0.55	1.58	0.91	0.53	1.50	0.88	0.51	1340	60	0.66	2.1	2.2	1.77	4	54	500
MS711-4	0.25	1.52	0.88	0.51	1.45	0.84	0.48	1.36	0.81	0.46	1350	60	0.72	2.2	2.4	1.73	6	55	500
MS712-4	0.37	2.02	1.17	0.67	1.92	1.11	0.64	1.86	1.07	0.62	1370	65	0.74	2.2	2.4	2.62	6	55	580
MS713-4	0.55	2.92	1.69	0.97	2.78	1.60	0.93	2.67	1.56	0.89	1380	66	0.75	2.2	2.4	3.85	6	57	650
MS801-4	0.65	2.87	1.66	0.96	2.74	1.58	0.91	2.60	1.52	0.89	1370	67	0.75	2.3	2.4	3.87	6	58	810
MS802-4	0.75	3.50	2.03	1.17	3.34	02.33.00	1.11	3.21	1.86	1.07	1380	72	0.78	2.2	2.4	5.27	6	58	910
MS803-4	1.1	4.86	2.81	1.62	4.63	2.67	1.54	4.45	2.57	1.48	1390	75.2	0.78	2.2	2.4	7.61	6	60	1100
MS90S-4	1.1	4.80	2.78	1.60	4.57	2.64	1.52	4.40	2.54	1.47	1400	75.2	0.79	2.2	2.4	7.60	6	61	1170
MS90L1-4	1.5	6.27	3.63	2.09	5.97	3.45	1.99	5.75	3.32	1.92	1400	79.5	0.8	2.2	2.4	10.36	6	61	1440
MS90L2-4	2.2	8.91	5.16	2.97	8.45	4.90	2.83	8.17	4.72	2.72	1400	81	0.8	2.2	2.4	14.90	7	63	1760
MS100L1-4	2.2	8.80	5.09	2.93	8.38	4.84	2.79	8.07	4.66	2.69	1420	81	0.81	2.1	2.3	14.90	7	64	1920
MS100L2-4	3	11.8	6.81	3.62	11.2	6.47	3.74	10.6	6.24	3.60	1420	82.6	0.81	2.2	2.3	20.32	7	64	2250
MS100L3-4	4	15.2	8.80	5.07	14.2	8.36	4.83	13.9	8.06	4.65	1430	84.2	0.82	2.2	2.3	26.93	7	65	2730
MS112M-4	4	15.0	8.70	5.01	14.3	8.26	4.77	13.8	7.96	4.59	1430	84.2	0.83	2.2	2.2	26.90	7	65	2900
MS112L-4	5.5	20.3	11.7	6.76	19.3	11.2	6.44	18.6	10.8	6.20	1440	86.7	0.83	2.2	2.2	36.74	7	68	3570
MS132S-4	5.5	20.1	11.6	6.68	19.1	11.0	6.37	18.4	10.6	6.13	1450	86.7	0.84	2.2	2.2	36.72	7	71	3900
MS132M-4	7.5	26.6	15.4	8.87	25.4	14.6	8.45	24.4	14.1	8.13	1450	87	0.85	2.2	2.2	50.12	7	71	4660
MS132L1-4	9.2	32.5	18.8	10.8	30.9	17.9	10.3	29.8	17.2	9.9	1460	87.5	0.85	2.2	2.2	60.13	7.5	74	5650
MS132L2-4	11	38.0	22.0	12.7	36.2	20.9	12.1	34.8	20.1	11.6	1480	88.4	0.86	2.2	2.2	71.74	7.5	74	6400
MS160M-4	11	37.5	21.7	12.5	35.8	20.6	11.9	34.4	19.9	11.5	1460	88.4	0.87	2.2	2.2	71.76	7	75	7300
MS160L1-4	15	51.2	29.6	17.1	48.8	28.2	16.3	46.6	27.1	15.6	1460	89.4	0.87	2.2	2.2	97.83	7.5	75	8650
MS160L2-4	18.5	63.1	36.5	21.0	60.1	34.7	20.0	57.9	33.5	19.3	1480	90.5	0.86	2.1	2.2	120	7.6	78	9750
MS180M-4	18.5	62.4	36.1	20.8	59.7	34.3	19.8	57.2	33.1	19.1	1460	90.5	0.86	2.2	2.2	143	7.5	80	1180
MS180L-4	22	73.6	42.7	24.7	70.6	40.6	23.4	67.7	38.1	22.6	1490	91	0.86	2.2	2.2	143	7.5	80	1380
MS200L-4	30	99.5	57.6	33.2	96.1	54.7	31.6	91.2	52.7	30.4	1470	92	0.86	2.2	2.2	196	7.5	83	1680

TECA Series - Three-Phase Asynchronous Single Speed Motors

IE1

Electrical data (50Hz) 6 poles

Frame size	Power (KW)	Current (A)			Current (A)			Current (A)			rpm. (r/min)	Eff. (%)	Power factor (Cosφ)	C _s /C _n	C _{max} /C _n	C _n (Nm)	I _s /I _n	dB(A)	Weight (Kg)
		220V	380V	660V	230V	400V	690V	240V	415V	720V									
MS 631-6	0.09	0.02	0.02	0.01	0.06	0.51	0.29	0.85	3.40	0.28	840	42	0.61	2	2	0.06	3.5	50	4.20
MS 632-6	0.12	1.13	0.65	0.38	1.06	0.62	0.36	1.03	0.60	0.34	850	45	0.62	2	2	1.18	3.5	50	4.50
MS 711-6	0.18	1.28	0.74	0.43	1.22	0.70	0.41	1.17	0.68	0.39	880	56	0.65	1.6	1.7	1.93	4	52	5.60
MS 712-6	0.25	1.59	0.92	0.53	1.51	0.87	0.50	1.46	0.84	0.49	900	59	0.7	2.1	2.2	2.36	4	52	6.00
MS 713-6	0.37	2.31	1.34	0.77	2.2	1.27	0.73	2.11	1.22	0.70	890	61	0.69	2	2.1	3.93	4	54	6.80
MS 801-6	0.37	2.24	1.30	0.75	2.13	1.23	0.71	2.05	1.19	0.68	900	62	0.7	1.9	1.9	3.90	4	56	8.10
MS 802-6	0.55	2.99	1.73	1.00	2.85	1.66	0.95	2.74	1.59	0.91	900	67	0.72	2	2.3	5.84	4	56	9.60
MS 803-6	0.75	4.02	2.33	1.34	3.83	2.21	1.28	3.69	2.13	1.23	900	68	0.72	2	2.3	7.88	4	58	10.00
MS 90S-6	0.75	3.96	2.29	1.32	3.77	2.18	1.26	3.63	2.10	1.21	930	69	0.72	2.2	2.2	7.83	5.5	59	11.30
MS 90L1-6	1.1	5.49	3.18	1.83	5.29	3.02	1.74	5.03	2.91	1.69	925	72	0.73	2.2	2.2	11.54	5.5	59	14.40
MS 90L2-6	1.5	7.09	4.11	2.35	6.76	3.90	2.25	6.59	3.76	2.17	925	74	0.75	2.2	2.2	15.64	5.5	60	15.50
MS 100L1-6	1.5	7.00	4.05	2.33	6.67	3.85	2.22	6.42	3.71	2.14	945	74	0.76	2.2	2.2	15.62	6	61	16.80
MS 100L2-6	2.2	9.87	5.71	3.29	9.40	5.43	3.13	9.04	5.23	3.01	960	77	0.76	2.2	2.2	22.31	6	63	19.80
MS 112M-6	2.2	9.7	5.64	3.25	9.28	5.38	3.09	8.83	5.15	2.98	955	78	0.76	2.2	2.2	22.34	6	64	25.00
MS 112L-6	3	12.9	7.46	4.31	12.3	7.12	4.11	11.9	6.86	3.95	960	79	0.77	2.2	2.2	30.21	6	64	30.00
MS 132S-6	3	13.1	7.59	4.37	12.5	7.21	4.16	12.0	6.95	4.01	960	79	0.76	2	2	30.18	6.5	64	35.00
MS 132M1-6	4	17.2	9.83	5.72	16.4	9.44	5.45	15.7	9.10	5.24	960	80.5	0.76	2	2	40.21	6.5	66	47.60
MS 132M2-6	5.5	22.6	13.1	7.53	21.5	12.4	7.17	20.7	12.0	6.9	960	83	0.77	2	2	55.32	6.5	68	60.70
MS 132L-6	7.5	30.1	17.4	10.0	28.7	16.5	9.55	27.6	15.9	9.2	960	85	0.77	2	2	74.60	6.5	68	47.60
MS 160M-6	7.5	28.6	16.6	9.5	27.3	15.7	9.08	26.2	15.2	8.7	980	86	0.8	2	2.2	74.58	6.5	68	70.0
MS 160L-6	11	41.8	24.2	13.9	39.8	23.0	13.3	38.3	22.1	12.8	960	87.5	0.79	2	2.2	109.43	6.5	73	87.0
MS 180L-6	15	54.6	31.6	18.2	52.2	30.0	17.3	50.1	28.9	16.7	970	89	0.81	2	2.2	147.73	6.5	79	122.0
MS 200L1-6	18.5	66.6	38.6	22.2	63.7	36.6	21.1	61.0	35.3	20.3	975	90	0.81	2	2.2	181.23	6.5	82	136.0
MS 200L2-6	22	77.9	44.7	26.6	73.6	42.6	24.5	70.6	41.0	23.6	975	90	0.83	2	2.2	216.21	6.5	88	162.0

TECA Series - Three-Phase Asynchronous Single Speed Motors

Electrical data (50Hz) - 8 poles

Frame size	Power (KW)	Current (A)			Current (A)			Current (A)			rpm. (r/min)	Eff. (%)	Power factor (Coef)	C _e /C _n	C _{max} /C _n	C _n (Nm)	I _s /I _n	dB(A)	Weight (Kg)
		220V	380V	660V	230V	400V	690V	240V	415V	720V									
MS 711-8	0.09	0.88	0.51	0.29	0.84	0.48	0.26	0.81	0.47	0.27	660	48	0.56	1.5	1.7	1.05	3	50	5.60
MS 712-8	0.12	1.05	0.61	0.35	1.00	0.56	0.33	0.96	0.55	0.32	660	51	0.59	1.6	1.7	1.63	2.7	50	6.00
MS 801-8	0.18	1.52	0.88	0.51	1.45	0.84	0.48	1.39	0.80	0.46	680	51	0.61	1.5	1.7	2.60	2.8	52	9.40
MS 802-8	0.25	1.92	1.11	0.64	1.83	1.06	0.61	1.76	1.02	0.59	660	56	0.61	1.6	2	3.60	2.7	52	10.10
MS 90S-8	0.37	2.45	1.42	0.82	2.33	1.35	0.78	2.24	1.30	0.75	680	63	0.63	1.6	1.8	5.22	2.8	56	12.50
MS 90L-8	0.55	3.36	1.95	1.12	3.21	1.85	1.07	3.08	1.78	1.03	660	66	0.65	1.6	1.8	7.03	3	56	15.30
MS 100L1-8	0.75	4.46	2.58	1.48	4.24	2.45	1.41	4.06	2.36	1.36	710	68	0.67	1.7	2.1	10.42	3.5	60	17.20
MS 100L2-8	1.1	5.81	3.36	1.94	5.54	3.20	1.85	5.33	3.08	1.78	710	72	0.69	1.7	2.1	15.18	3.5	59	19.50
MS 112M-8	1.5	7.82	4.53	2.61	7.45	4.30	2.48	7.17	4.15	2.39	710	74	0.68	1.8	2.1	20.63	4.2	61	25.50
MS 132S-8	2.2	10.8	6.28	3.61	10.3	5.96	3.44	9.94	5.75	3.31	720	75	0.71	2	2	29.82	5.5	64	34.20
MS 132M-8	3	14.0	8.11	4.67	13.3	7.70	4.45	12.8	7.43	4.28	720	77	0.73	2	2	42.35	5.5	64	40.00
MS 160M1-8	4	18.0	10.4	5.99	17.1	9.99	5.71	16.5	9.53	5.49	730	80	0.73	1.9	2.1	53.81	6	68	59.00
MS 160M2-8	5.5	23.4	13.5	7.79	22.3	12.9	7.42	21.4	12.4	7.14	720	83.5	0.74	2	2.2	73.27	6	68	99.00
MS 160L-8	7.5	30.9	17.9	10.3	29.4	17.0	9.8	28.3	16.4	9.43	720	85	0.75	1.9	2.2	100.65	6	68	87.00
MS 180L-8	11	45.2	26.2	15.1	43.6	25.1	14.5	41.5	24.0	13.8	715	87.4	0.73	1.9	2.2	144.2	6	78	125.0
MS 200L-8	15	58.9	34.1	19.6	56.3	32.4	18.7	54.0	31.2	18.0	725	88.0	0.78	1.9	2.2	194.65	8	80	151.0

TECA Series - Three-Phase Asynchronous Single Speed Motors

Electrical data (50Hz) 2poles **IE2**

Frame size	Power (KW)	Eff. (%)	Current I(A) 400V	Power factor (Cosφ)	rpm (rpm/min)	Cn (Nm)	Cs/Cn	Ia/Ic
MS2 801-2	0.75	77.4	1.75	0.80	2840	2.40	2.9	5.8
MS2 802-2	1.1	80	2.42	0.82	2850	3.53	3.5	6.8
MS2 90S-2	1.5	81.4	3.20	0.83	2850	5.09	3.5	6.9
MS2 90L-2	2.2	83.2	4.54	0.84	2850	7.32	4.1	7.9
MS2 100L-2	3	84.6	5.88	0.87	2880	9.68	3.4	7.8
MS2 112M-2	4	86	7.54	0.89	2890	13.16	2.7	7.5
MS2 132S1-2	5.5	87.2	10.2	0.88	2900	18.25	2.4	7.7
MS2 132S2-2	7.5	88.1	13.8	0.89	2910	24.47	2.6	8.4
MS2 160M1-2	11	89.4	19.9	0.90	2930	30.23	2.4	7.6
MS2 160M2-2	15	90.3	26.9	0.89	2930	37.68	2.6	8
MS2 160L-2	18.5	90.9	32.8	0.90	2940	33.42	3	9
MS2 180M-2	22	91.3	38.6	0.90	2950	38.11	2.6	8.5
MS2 200L1-2	30	92	52.3	0.90	2950	51.93	2.4	8
MS2 200L2-2	37	92.5	64.1	0.90	2950	63.48	2.5	8.5

Electrical data (50Hz) 4 poles **IE2**

Frame size	Power (KW)	Eff. (%)	Current I(A) 400V	Power factor (Cosφ)	rpm (rpm/min)	Cn (Nm)	Cs/Cn	Ia/Ic
MS2 802-4	0.75	79.6	1.79	0.75	1410	5.27	2.8	5.3
MS2 90S-4	1.1	81.4	2.50	0.75	1420	7.51	3.8	6.7
MS2 90L-4	1.5	82.8	3.31	0.79	1420	10.39	4	7.2
MS2 100L1-4	2.2	84.3	4.83	0.75	1440	14.76	3.6	7.4
MS2 100L2-4	3	85.5	6.30	0.80	1440	20.13	3.8	7.8
MS2 112M-4	4	86.6	8.23	0.81	1440	26.89	3.1	7.1
MS2 132S-4	5.5	87.9	10.9	0.83	1450	35.25	2.6	7.4
MS2 132M-4	7.5	88.7	14.5	0.84	1450	48.21	2.8	7.7
MS2 160M-4	11	89.8	21.6	0.82	1450	71.86	2.7	7.7
MS2 160L-4	15	90.6	28.4	0.84	1450	97.90	2.4	7.3
MS2 180M-4	18.5	91.4	34.4	0.85	1460	121.32	2.2	7.4
MS2 180L-4	22	91.7	40.3	0.86	1460	143.26	2.3	7.5
MS2 200L-4	30	92.3	55.2	0.86	1470	195.54	2.8	7.6

TECA Series - Three-Phase Asynchronous Single Speed Motors

Electrical data (50Hz) 6 poles **IE2**

Frame size	Power (KW)	Eff. (%)	Current I _n (A) 400V	Power factor (Coef)	rpm (rpm/min)	C _n (Nm)	C _s /C _n	I _s /I _n
MS2 90S-6	0.75	78.0	2.01	0.71	925	7.75	3.1	4.7
MS2 90L-6	1.1	73.1	2.82	0.72	900	11.43	3.2	5
MS2 100L-6	1.5	80.0	3.71	0.73	940	15.09	3.1	5.9
MS2 112M-6	2.2	81.8	5.17	0.75	945	22.13	2.6	5.6
MS2 132S-6	3	83.3	6.84	0.76	960	30.32	2.2	5.7
MS2 132M1-6	4	84.6	8.85	0.77	960	41.25	2.4	6.2
MS2 132M2-6	5.5	86	12.0	0.77	960	54.86	2.6	6.7
MS2 160M-6	7.5	87.5	16.1	0.77	975	74.09	2	6.6
MS2 160L-6	11	89.0	22.9	0.78	970	108.92	2	5.8
MS2 180L-6	15	90.1	29.9	0.83	975	147.77	1.9	7.5
MS2 200L1-6	18.5	90.4	35.6	0.83	975	183.32	2.2	6.3
MS2 200L2-6	22	90.9	41.6	0.84	975	214.53	2.3	06.02

TECA Series - Overall & Installation Dimensions

All dimensions in mm

TECA MS B3

Table 1

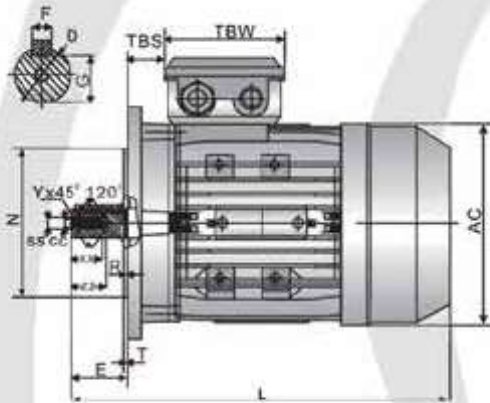
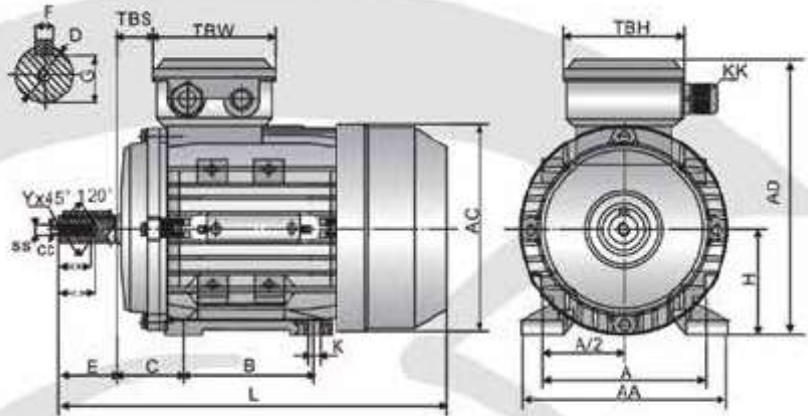

TECA MS B5

Table 2

TECA MS B14

Table 2

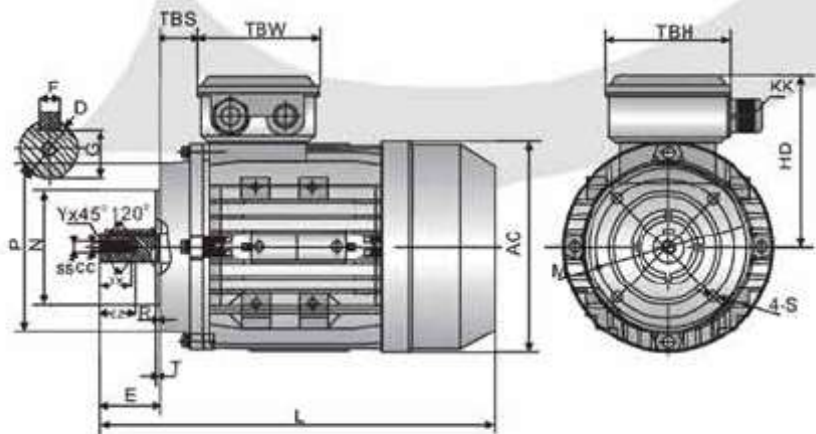

TECA Series - Overall & Installation Dimensions

Table 1

Frame Size	B3					Shaft							General							
	H	A	B	C	K	D	E	F	G	SS	XX	ZZ	AA	AD	HD	AC	L	TBS	TBW	TBH
56	56	90	71	36	5.8 x 8.8	Ø9	20	3	7.2	M3	9	12	110	156	100	Ø117	196	14	14	88
63	63	100	80	40	7 x 10	Ø11	23	4	8.5	M4	10	14	120	171	108	Ø130	220	14	14	94
71	71	112	90	45	7 x 10	Ø14	30	5	11	M5	12	17	132	186	115	Ø147	241	20	20	94
80	80	125	100	50	10 x 13	Ø19	40	6	15.5	M6	16	21	160	213	133	Ø163	290	27	27	105
90S	90	140	100	56	10 x 13	Ø24	50	8	20	M8	19	25	175	229	139	Ø183	312	30	30	105
90L1/L2	90	140	125	56	10 x 13	Ø24	50	8	20	M8	19	25	175	229	139	Ø183	337/367	30	30	105
100	100	160	140	63	12 x 15	Ø28	60	8	24	M10	22	30	198	252	152	Ø205	368	26	26	105
112	112	190	140	70	12 x 15	Ø28	80	8	24	M10	22	30	220	279	167	Ø229	395	32	32	112
132S	132	216	140	89	12 x 15	Ø38	80	10	33	M12	28	37	252	318	186	Ø265	437	38	38	112
132M/L	132	216	178	89	12 x 15	Ø38	80	10	33	M12	28	37	252	318	186	Ø265	475/501	38	38	112
160M/L	160	254	210/254	108	15 x 19	Ø42	110	12	27	M16	36	45	290	384	224	Ø325	640	64	64	143
180M/L	180	279	241/279	121	15 x 19	Ø48	110	14	42.5	M16	36	45	340	440	260	Ø368	730	73	73	190
200L	200	318	305	133	19 x 29	Ø55	110	16	49	M20	42	53	390	460	260	Ø368	745	85	85	190

Table 2

Frame Size	B5						B5R						B14						B14B						
	M	N	P	T	S	R	M	N	P	T	S	R	N	M	P	T	S	R	N	M	P	T	S	R	
56	Ø100	Ø80	Ø120	3.0	Ø7	0							Ø50	Ø65	Ø80	2.5	M5	0							
63	Ø115	Ø95	Ø140	3.0	Ø10	0							Ø60	Ø75	Ø90	2.5	M5	0	Ø80	Ø100	Ø120	3.0	M6	0	
71	Ø130	Ø110	Ø160	3.5	Ø10	0	Ø115	Ø95	Ø140	3.5	Ø10	0	Ø70	Ø85	Ø105	2.5	M6	0	Ø95	Ø115	Ø140	3.0	M8	0	
80	Ø165	Ø130	Ø200	3.5	Ø12	0	Ø130	Ø110	Ø160	3.5	Ø10	0	Ø80	Ø110	Ø120	3.0	M6	0	Ø110	Ø130	Ø160	3.5	M8	0	
90S	Ø165	Ø130	Ø200	3.5	Ø12	0	Ø130	Ø110	Ø160	3.5	Ø10	0	Ø95	Ø115	Ø140	3.0	M8	0	Ø110	Ø130	Ø160	3.5	M8	0	
90L1/L2	Ø165	Ø130	Ø200	3.5	Ø12	0	Ø130	Ø110	Ø160	3.5	Ø10	0	Ø95	Ø115	Ø140	3.0	M8	0	Ø110	Ø130	Ø160	3.5	M8	0	
100	Ø215	Ø180	Ø250	4.0	Ø15	0	Ø165	Ø130	Ø200	4.0	Ø12	0	Ø110	Ø130	Ø160	3.5	M8	0	Ø130	Ø165	Ø200	3.5	M10	0	
112	Ø215	Ø180	Ø250	4.0	Ø15	0	Ø165	Ø130	Ø200	4.0	Ø12	0	Ø110	Ø130	Ø160	3.5	M8	0	Ø130	Ø165	Ø200	3.5	M10	0	
132S	Ø265	Ø230	Ø300	4.0	Ø15	0	Ø215	Ø180	Ø250	4.0	Ø15	0	Ø130	Ø165	Ø200	4.0	M10	0	Ø180	Ø215	Ø250	4.0	M12	0	
132M/L	Ø265	Ø230	Ø300	4.0	Ø15	0	Ø215	Ø180	Ø250	4.0	Ø15	0	Ø130	Ø165	Ø200	4.0	M10	0	Ø180	Ø215	Ø250	4.0	M12	0	
160M/L	Ø300	Ø250	Ø350	5.0	Ø19	0							Ø180	Ø215	Ø250	4.0	M10	0							
180M/L	Ø300	Ø250	Ø350	5.0	Ø19	0																			
200L	Ø300	Ø300	Ø400	5.0	Ø19	0																			